

TECHNICAL MANUAL

**OPERATOR'S, UNIT AND
DIRECT SUPPORT MAINTENANCE MANUAL
(INCLUDING REPAIR PARTS AND SPECIAL TOOLS LIST)
FOR**

**PRECISION GENERAL PURPOSE WATER
BATHS**

MODEL TS-66518 AW-9

NSN 6640-00-403-0420

This technical manual is an authentication of the manufacturer's commercial literature and does not conform with the format and the content requirements normally associated with Army technical manuals. This technical manual does, however, contain all essential information required to operate and maintain the equipment.

Approved for public release; distribution is unlimited.

**HEADQUARTERS, DEPARTMENT OF THE ARMY
28 SEPTEMBER 1990**

This technical manual is an authentication of the manufacturer's commercial literature and does not conform with the format and the content requirements normally associated with Army technical manuals. This technical manual does, however, contain all essential information required to operate and maintain the equipment.

Approved for public release; distribution is unlimited.

SUPPLEMENTARY INTRODUCTORY MATERIAL

1-1. Maintenance Forms and Records.

Department of the Army forms and procedures used for equipment maintenance will be those described by DA Pam 738-750, The Army Maintenance Management System.

1-2. Reporting Errors and Recommending Improvements.

You can help improve this manual. If you find any mistakes or if you know of a way to improve the procedures, please let us know. Mail your letters, DA Form 2028 (Recommended Changes to Publications and Blank Forms), or DA Form 2028-2 located in the back of this manual, directly to Commander, U S. Army Troop Support Command, ATTN: AMSTR-MCTS, 4300 Goodfellow Blvd., St. Louis, MO 63120-1798 A reply will be furnished to you.

1-3. Destruction of Army Material to Prevent Enemy Use

Refer to TM 750-244-3 for instructions covering the destruction of Army Material to prevent enemy use

1-4. Administrative Storage of Equipment.

a. Placement of equipment in administrative storage should be for short periods of time when a shortage of maintenance effort exists. Items should be in mission readiness within 24 hours or within the time factors as determined by the directing authority. During the storage period appropriate maintenance records will be kept.

b. Before placing equipment in administrative storage, current preventive maintenance checks and services should be completed. Shortcomings and deficiencies should be corrected, and all modification work orders (MWO's) should be applied.

c. Storage site selection. Inside storage is preferred for items selected for administrative storage. If inside storage is not available, trucks, vans, conex containers and other containers may be used

Precisionâ

Instruction Manual TS-66518 AW-9



Precision Scientific

General Purpose Water Baths

Introduction

Your satisfaction and safety are important to PRECISION® SCIENTIFIC and a complete understanding of this unit is necessary to attain these objectives.

As the ultimate user of the apparatus, it is your responsibility to understand its proper function and operational characteristics. This instruction manual should be thoroughly read and all operators should be given adequate training before attempting to place this unit in service. Awareness of the stated cautions and warnings, and compliance with recommended operating parameters -- together with maintenance requirements -- are important for safe and satisfactory operation. The unit should be used for its intended application; alterations or modifications will void the Warranty.

WARNING: As a routine laboratory precaution, always wear safety glasses when working with this apparatus.

This product is not intended, nor can it be used, as a sterile or patient connected device. In addition, this apparatus is not designed for use in Class I, II, or III locations as defined by the National Electrical Code.

Unpacking and damage

Save all packing material if apparatus is received damaged. This merchandise was carefully packed and thoroughly inspected before leaving our factory.

Responsibility for its safe delivery was assumed by the carrier upon acceptance of the shipment; therefore, claims for loss or damage sustained in transit must be made upon the carrier by the recipient as follows:

Visible Loss or Damage: Note any external evidence of loss or damage on the freight bill, or express receipt, and have it signed by the carrier's agent. Failure to adequately describe such external evidence of loss or damage may result in the carrier's refusing to honor your damage claim. The form required to file such a claim will be supplied by the carrier.

Concealed Loss or Damage: Concealed loss or damage means loss or damage which does not become apparent until the merchandise has been unpacked and inspected. Should either occur, make a written request for inspection by the carrier's agent within 15 days of the delivery date; then file a claim with the carrier since the damage is the carrier's responsibility.

By following these instructions carefully, we guarantee our full support of your claim to be compensated for loss from concealed damage.

DO NOT -- FOR ANY REASON -- RETURN THIS UNIT WITHOUT FIRST OBTAINING AUTHORIZATION. In any correspondence to PRECISION® SCIENTIFIC, please supply the nameplate, date, including catalog number and serial number.

General information These instructions encompass General Purpose Water Baths (see chart below), but the operation and maintenance of each are similar. The General Purpose Baths are ideal for a wide variety of serological research procedures and a broad range of other general laboratory applications.

Precision water baths feature a one piece, deep-drawn stainless steel chamber, welded and painted stainless steel outer body. The model 181 comes equipped with a plastic cover, all others models are equipped with a stainless steel cover to provide faster temperature recovery and reduced power consumption.

The support shelf, provided with each model from 181 and above is adjustable to three varying height levels by simply changing the position of the legs. The Model 180 is equipped with a non-adjustable diffuser shelf.

Depending on the model, one (1), or two (2), heaters are attached to the bottom of the bath chamber.

The following water bath capacities were measured with water levels approximately 1-1/2" from chamber top; 1/2" from chamber top for Model 180.

CATALOG NO.	MODEL NO.	ELECTRICAL CHARACTERISTICS			CAPACITY	
		Volts	Watts	Amps	Liters	Gallons
66630	180	120	225	1.9	2	0.5
66557	181	120	225	1.9	2.2	0.58
66564	181	240	225	0.9	2.2	0.58
66643	182	120	300	2.5	5.3	1.4
66617	182	240	300	1.3	5.3	1.4
66551	183	120	400	3.4	11	3.0
66553	183	240	400	1.7	11	3.0
66648	184	120	600	5.0	19	5.0
66618	184	240	600	2.5	19	5.0
66562	185	120	600	5.0	17	4.4
66563	185	240	600	2.5	17	4.4
66634	186	120	1200	10.0	50	13.2
66647	186	240	1200	5.0	50	13.2
66552	188 Dual	120	800	6.7	8.3(Sm.)	2.2(Sm.)
66554	188 Dual	240	800	3.3	11(Lg.)	3.0(Lg.)

Installation

Location: The most uniform operating conditions and results will be obtained by placing the bath in an area remote from drafts, ventilating outlets, radiators, and other rapidly changing ambient conditions.

Cleaning: The interior of the bath, shelf platform, and cover should be washed with a mild detergent solution and rinsed with distilled water.

Electrical Connections: Important (Please Read Carefully.)

CAUTION: DO NOT connect bath to power supply unless bath is filled with at least 1" of water and the line switch is in the "Off" position. This will prevent the heater from burning out.

WARNING: For personal safety, this apparatus must be properly grounded.

The power cord of this instrument is equipped with a three-prong (grounding) plug which mates with a standard three prong (grounding) wall receptacle to minimize the possibility of electric shock hazard from this apparatus. The user should have the wall receptacle and circuit checked by a qualified electrician to make sure the receptacle is properly grounded. Where a two-prong receptacle is encountered, it is the personal responsibility and obligation of the user to have it replaced with a properly grounded three-prong wall receptacle.

WARNING:DO NOT, under any circumstance, cut or remove the third (ground) prong from the power cord. DO NOT use a two-prong adapter plug.

Determine the total amount of current presently being used by other apparatus connected to the circuit that will be used for this unit. It is critical that the added current demand and other equipment on the circuit not exceed the rating of the fuse or circuit breaker in use.

CAUTION: Be sure the power supply is of the same voltage as specified on the nameplate.

Operation

Before filling, check line switch to be sure it is in the "Off" position. Adjust the diffuser pan legs so that the pan will be at the desired depth when the water level is within 1-1/2" of top.

NOTE: Legs are not supplied on the Model 180.

Fill bath with distilled water, making allowance for displacement by the sample(s) to be immersed, and for expansion of the media upon reaching operating temperature. The maximum liquid level should be 1-1/2" from top surface of the bath after object(s) are immersed.

NOTE: Distilled water is recommended. Distilled water will not cause corrosion to the bath chamber, and cleaning of the bath will be less frequent.

OPERATION (Contd.)

For Model 180, place the stainless steel metal tray (corners turned downward) inside the bath chamber. The tray provides a sample base and protects samples from touching the hot metal bath bottom. Fill bath with distilled water to within 3/4" of top of bath, allowing for displacement by sample(s) to be immersed, and for expansion of the media upon reaching operating temperature.

NOTE: To conserve energy and to reduce evaporation, use a cover throughout the temperature range of the bath. Do not use aluminum foil as a cover; it may cause corrosion to the stainless steel as a result of an electrolytic reaction.

Each bath is supplied with a thermometer holder (metal clip) fastened to the top of the bath and a thermometer and O-ring packed separately. Slip O-ring onto thermometer, then insert thermometer through metal clip until line indicating immersion depth is at or below the water surface. When the shelf is in its highest position, the immersion line may be above the water line; however, the thermometer bulb should be located above the diffuser pan.

CAUTION: Care should be taken to protect the thermometer from accidental breakage and spillage of hazardous mercury content.

Insert line cord into the proper receptacle and turn line switch to the "On" position. This action will energize the heater and cause the red pilot lamp to turn "On" and stay lit while the heater(s) is energized. Set thermostat dial, as explained below, to obtain the desired temperature setting.

CAUTION: Exercise care when using acidic or caustic solutions, as they will attack the stainless steel bath body if spillage into the bath should occur.

Clean and remove any spillage and condensation from all sheet metal surfaces after each test. If spillage into the bath medium has occurred, the liquid should be drained and the unit thoroughly flushed.

OPERATION (Contd.)

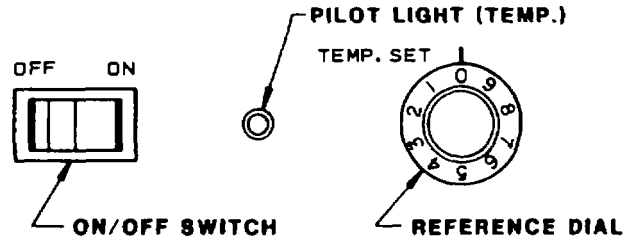

Models 180-186

(Model 188 has a double configuration of the above.)

Setting Thermostat: A reference dial is provided to correlate thermostat setting with temperature readings taken from the mercury-in-glass thermometer.

NOTE: Reference dial numbers are for reference only and are not values for water temperature within the unit.

To determine what temperatures may be expected from various settings on the dial, select an arbitrary setting of "4" by turning the control knob in a clockwise direction. (With warmer water, a higher setting may be necessary.) With the dial set at "4" or higher, the neon-glow pilot lamp is energized. Temperature equilibrium will be indicated by a steady cycling of this lamp from "On" to "Off" approximately every minute. At this point, a temperature reading should be taken from the thermometer and noted.

It is suggested that the above procedure be repeated at progressively higher settings on the reference dial. Approach all settings in a "clockwise" direction. This means that when changing from a high setting to a lower one, the control knob should be turned back past the lower setting desired and then approached in a "clockwise" direction.

Servicing

Cleaning: To remove algae and to clean the bath, a detergent solution is recommended. Should algae or any other undesirable microorganisms form on top of the bath media, add a little formaldehyde or zephiran chloride to alleviate this problem.

WARNING: Unit must be disconnected from power source prior to servicing. It is recommended that all service be performed by qualified service personnel.

SERVICE (Contd.)

NOTE: Assembly and disassembly of these water baths for servicing will require a special tool for removal of TORX® type screws. The tool necessary is a TORX® T-25 key and maybe purchased at your local auto parts or hardware store.

General Information: To service the water bath, turn it on its side or top, remove bottom plate and insulation. To prevent scratching of the enameled surface, place protective material (cardboard, cloth, or newspaper) under unit.

Leaks: Should a leak develop, drain bath and remove shelf. Turn bath upside down and remove bottom plate and insulation. Leakage is only possible through the thermostat capillary fitting. Therefore, check locknut to see if it is tight, or if O-ring needs to be replaced.

Thermostat Replacement: Replace thermostat if bath water does not heat and pilot light remains "off." Follow the steps below to remove the thermostat.

CAUTION: Care must be exercised when handling the thermostat capillary, since a sharp bend will crimp off the flow of the hydraulic operating medium. To avoid twisting the capillary or damaging O-ring, hold the fitting under the bath stationary, and firmly tighten locknut inside bath chamber. Do not over-tighten, as O-ring could be squeezed out of position, causing bath to leak. Under-tightening will also cause the bath to leak.

1. Disconnect power to bath and put switch in "Off" position.
2. Remove shelf and drain bath.
3. Remove thermostat control knob by loosening two set screws on knob.
4. Place bath on its side and remove bottom plate and insulation to gain access to thermostat fitting.
5. Remove two screws fastening thermostat to control panel.
6. Remove wires from thermostat terminals.
7. Hold the fitting under the bath stationary, unscrew locknut inside bath chamber, and remove from capillary.
8. Feed thermostat capillary out through hole in bottom of chamber.
9. Replace O-ring on bottom side of chamber with new Viton O-ring.
10. Complete installation by reversing above procedure. Be certain all wiring is away from heater. Insulation must be replaced between heater and bottom plate to prevent possible wire shorting.

SERVICE (Contd.)

<u>HEATER DATA</u>				
<u>Cat. No.</u>	<u>Model</u>	<u>Heater Wattage</u>	<u>Voltage</u>	<u>Resistance (Ohms)</u>
66630	180	225	120	64
66557	181	225	120	64
66564	181	225	240	256
66643	182	300	120	48
66617	182	300	240	192
66551	183	400	120	36
66553	183	400	240	144
66648	184	600	120	24
66618	184	600	240	96
66562	185	600	120	24
66563	185	600	240	96
66634	186	2(600)	120	24
66647	186	2(600)	240	96
66552	188	2(400)	120	36
66554	188	2(400)	240	144

Heater Resistance Procedure:

WARNING: Disconnect the bath from its power source.

Refer to the appropriate wiring diagram and the table above for resistance values at room temperature. Resistance is measured between terminals on the heater element.

Be sure to disconnect at least one lead of each heater before taking an ohmmeter reading.

If the heater is open (infinite resistance), it should be replaced.

Heater Replacement:

WARNING: Service should be performed by qualified service personnel.

SERVICE (Contd.)

1. Place "ON-OFF" switch in "Off" position and disconnect power to bath.
2. Remove shelf, thermometer and drain the bath.
3. Turn bath upside down. Remove mounting screws, bottom plate and mica insulation.
4. Remove nuts that fasten the heater retaining bracket and heater from the bottom of tank.
5. Remove above components and old heater from the bottom of tank, and remove Fiberflax insulation from the old heater. New heater assembly is shown below.
6. Insert Fiberflax insulation into the replacement heater, and fasten the heater to the bottom of the tank.

WARNING: Be sure heater terminals are pointing away from the bottom of the tank to eliminate electrical short. Do not crimp or sharply bend the thermostat capillary as erratic temperature control will result. Be sure that the capillary does not touch the heater(s).

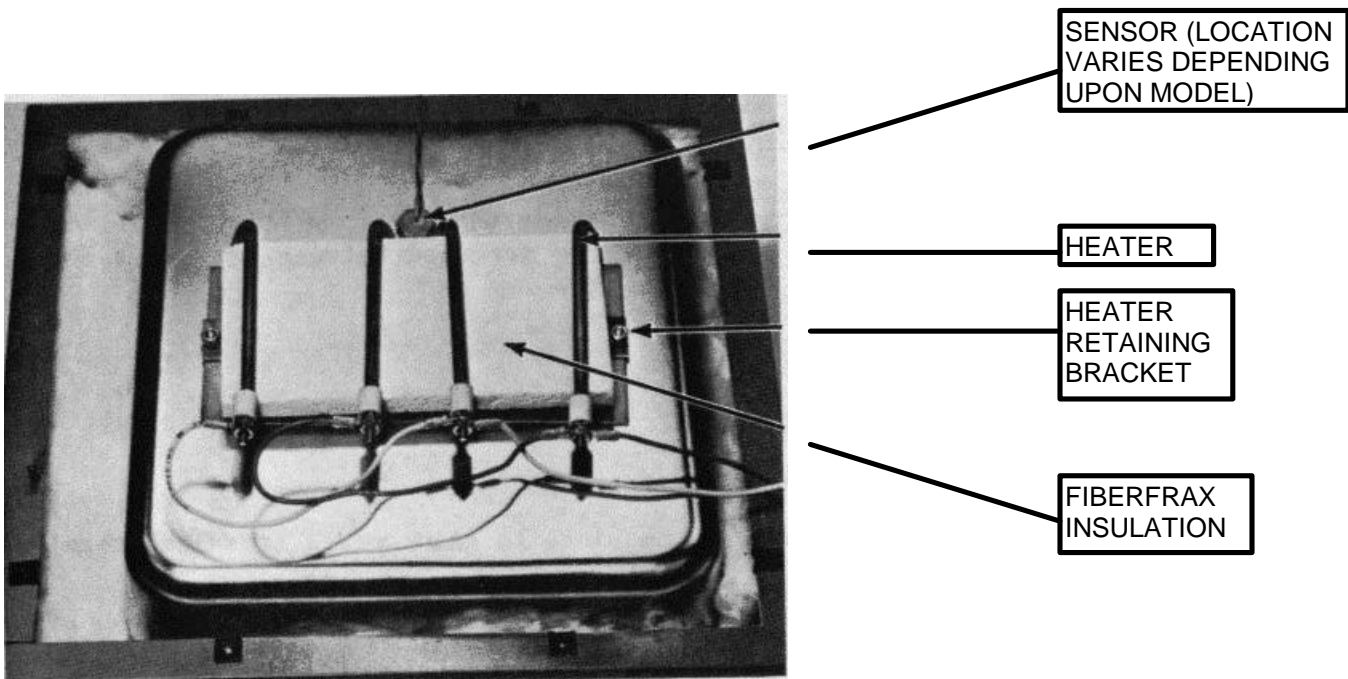

SERVICE (Contd.)

7. Check heater for proper ground by placing ohmmeter leads between heater sheath and bath body grounding screw. Reading should be zero ohms.

CAUTION: Upon completion of heater installation, check to be sure that the wires do not touch the new coil heater. Route all wires away from heater.

8. Replace mica insulation, bottom plate and mounting screws. Turn bath upright and fill tank with water.

Pilot Light Replacement:

If the pilot light(s) remains "off" when the bath is "on" and properly functioning, follow these steps in replacing the pilot light(s):

1. Disconnect power to bath and put switch in "Off" position.
2. Remove shelf and drain bath.
3. Place bath on its top and remove bottom plate.
4. Disconnect pilot light leads.
5. Push pilot light(s) out through hole in control panel.
6. Complete installation by reversing above procedure. Be certain all wiring is away from heater(s). Insulation must be replaced between heater(s) and bottom plate to prevent possible wire shorting.

Switch Replacement:

1. Disconnect power to bath and put switch in "Off" position.
2. Remove shelf and drain bath.
3. Place bath on its top; remove bottom plate to gain access to switch terminals.
4. Disconnect wires from switch terminals.
5. Switch is fastened to control panel with two spring clips. Depress clips and remove switch(es).
6. Complete installation by reversing above procedure. New switch(es) must be in "Off" position.
7. All wiring should be away from heater. Make certain that mica insulation is placed between heater and bottom plate to prevent possible wire shorting.

Parts list

<u>Description</u>	<u>Symbol</u>	<u>180</u>	<u>181</u>	<u>182</u>	<u>183</u>	<u>184</u>	<u>185</u>	<u>186</u>	<u>188</u>
1. Pilot Light Assem. (120V)	DS1 (2)	234174	537979	537979	234174	234174	234174	234174	234174
2. Pilot Light Assem. (240V)	DS1 (2)	N/A	537980	537980	234175	234175	234175	234175	234175
3. Switch, D.P.S.T. (120V) & (240V)	S1 (2)	240526	240304	240304	240304	240304	240304	240304	240304
4. Thermostat*	S2	239137	239137	239137	239137	239137	239137	239137	239137 (2)
5. Heater, 120V	HR1/HR2	247398	247398	247346	247347	247348	247348	247348 (2)	247347 (2)
6. Heater, 240V	HR1/HR2	N/A	247399	247346	247347	247348	247348	247348 (2)	247347 (2)
7. Thermometer Bracket	N/A	537771	537771	537771	537771	533772	537771	53772	537771 (2)
8. O-Ring*, Viton	N/A	232125	232125	232125	232125	232125	232125	232125	232125 (2)
9. Thermometer	N/A	307053	31495	31495	31495	31495	31495	31495	31495 (2)
10. O-Ring, Thermometer	N/A	232070	232070	232070	232070	232070	232070	232070	232070 (2)
11. Knob, Thermostat	N/A	220177	220177	220177	220177	220177	220177	220177	220177 (2)
12. Insulation, 1/2" Thk. Fiberfrax Duraboard	N/A	00637401	00637401	00637402	00637403	00637404	00637404	00637404 (2)	00637403 (2)
13. Bracket, Heater Retaining (2/Heater)	N/A	00404101	00404101	00404101	00404101	00404101	00404101	00404101	00404101
14. Insulation, Mica	N/A	00559503	00559402	00559502	00559802	00559602	00560002	00559702	00559902

*When replacing thermostat, also replace O-Ring. Discard copper O-Ring supplied with thermostat and use new 232125 Viton O-Ring.

WIRING DIAGRAMS

MODEL 180, 120V.
 MODEL 181, 120V AND 240V.

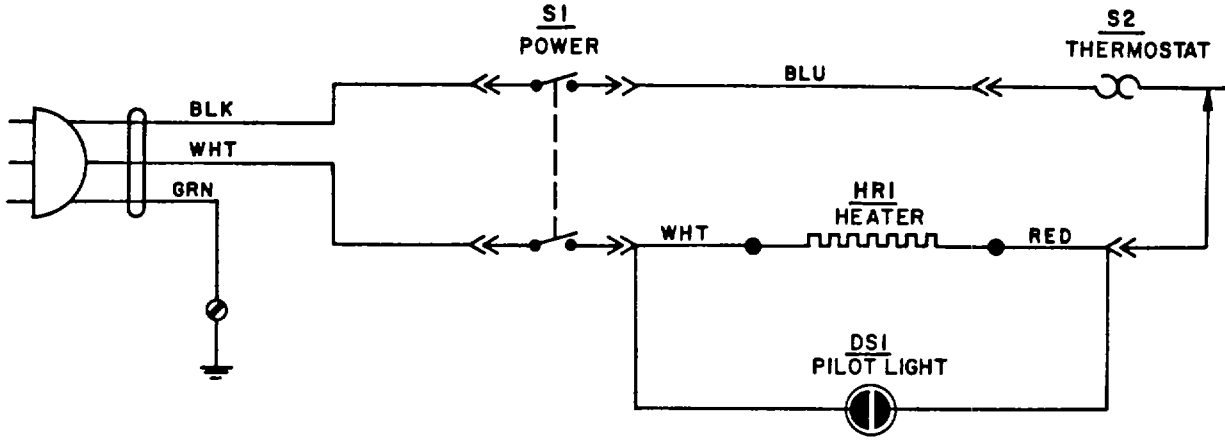

MODEL 182, 183, 184, 185, 120V.

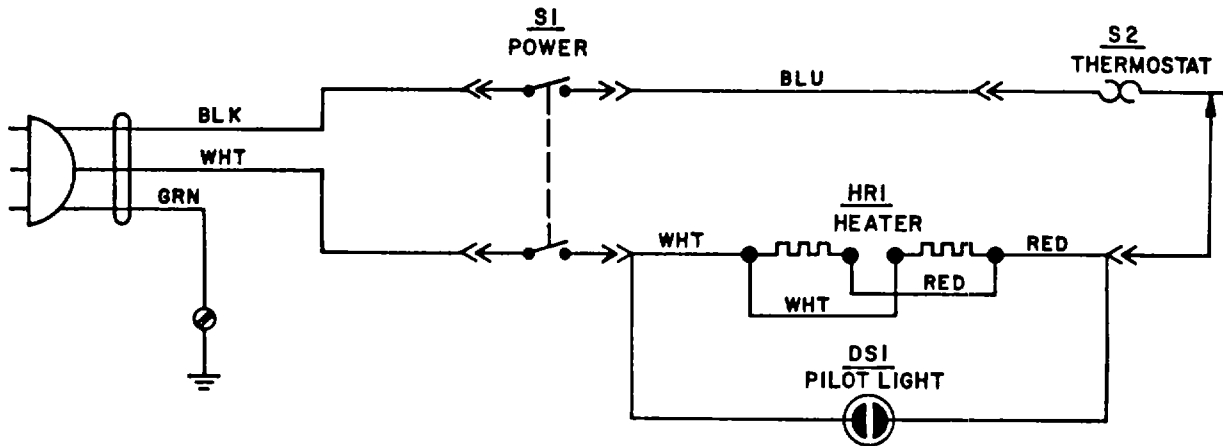

WIRING DIAGRAM

MODEL 182, 183, 184, 185, 240V.

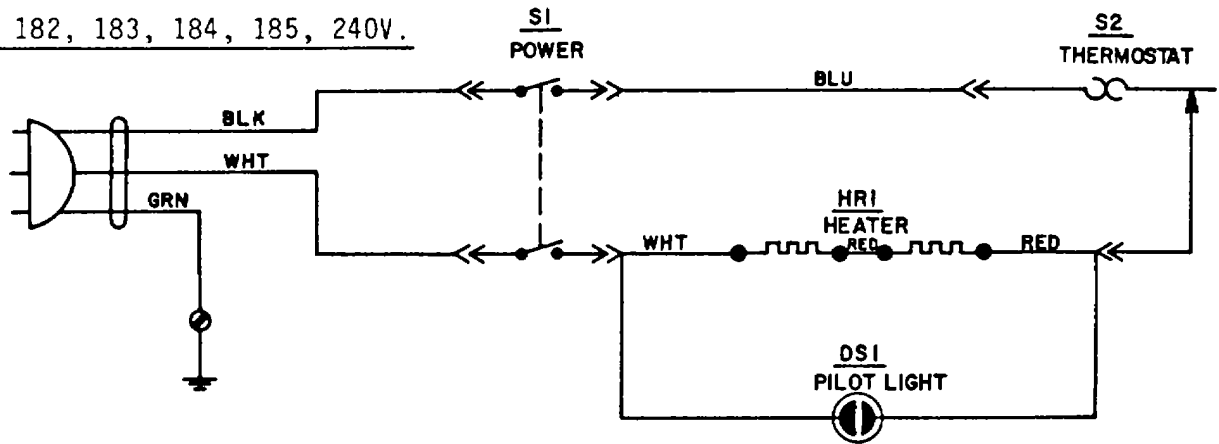

MODEL 186, 120V.

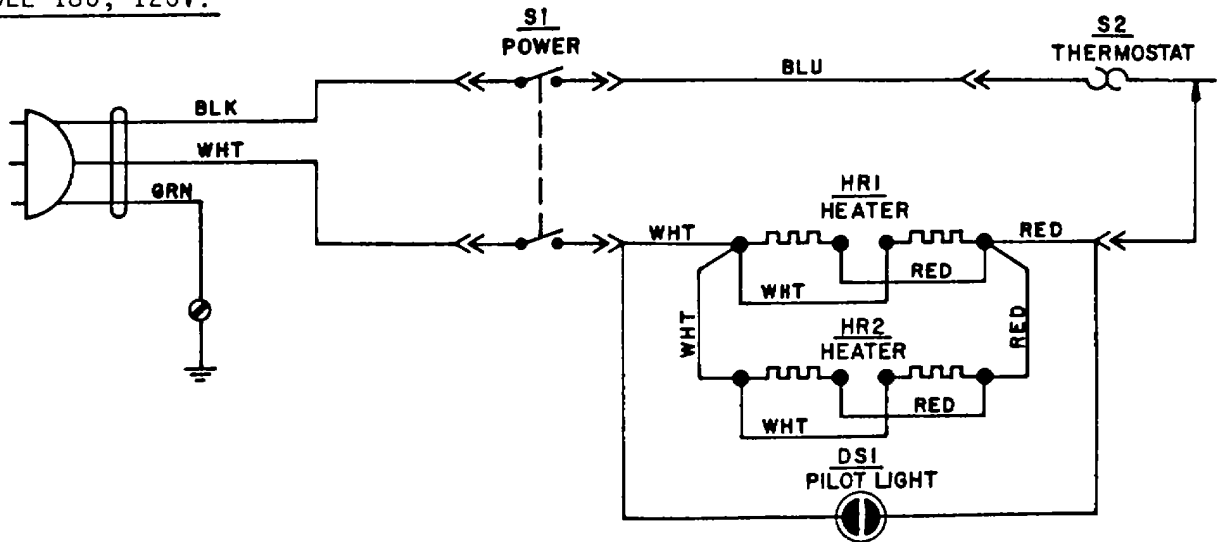

MODEL 186, 240V.

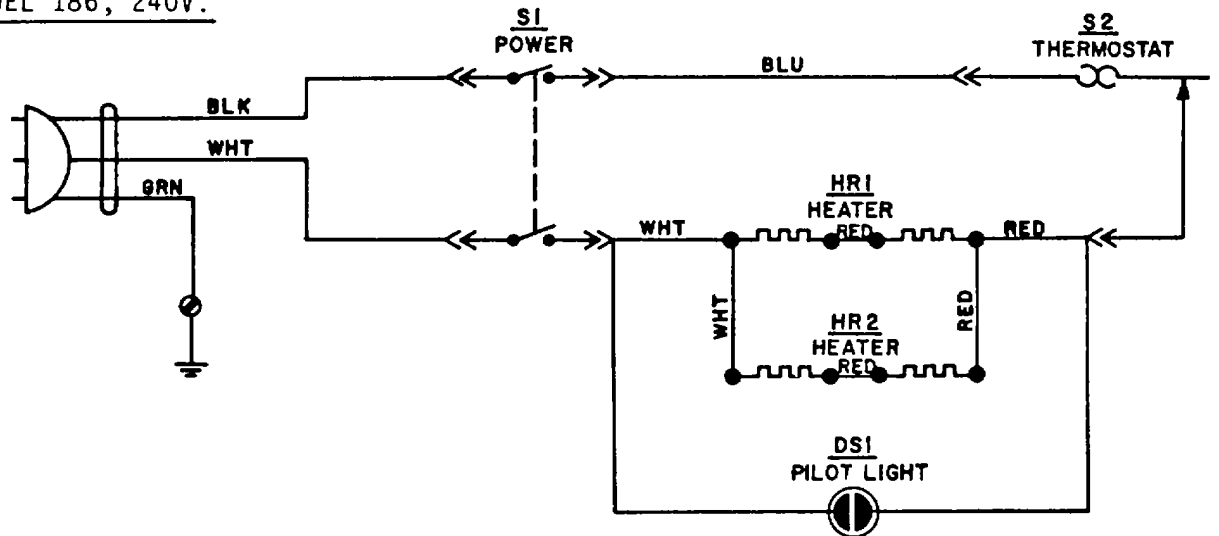

WIRING DIAGRAM

MODEL 188 DUAL BATH, 120V

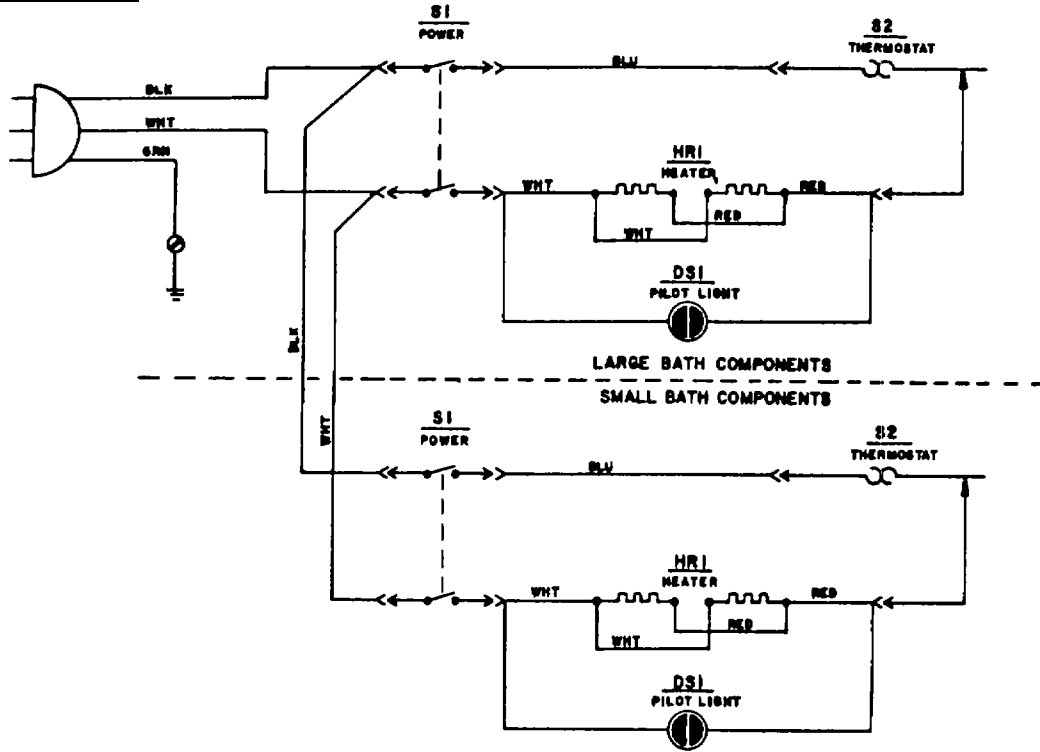

MODEL 188 DUAL BATH, 240V.

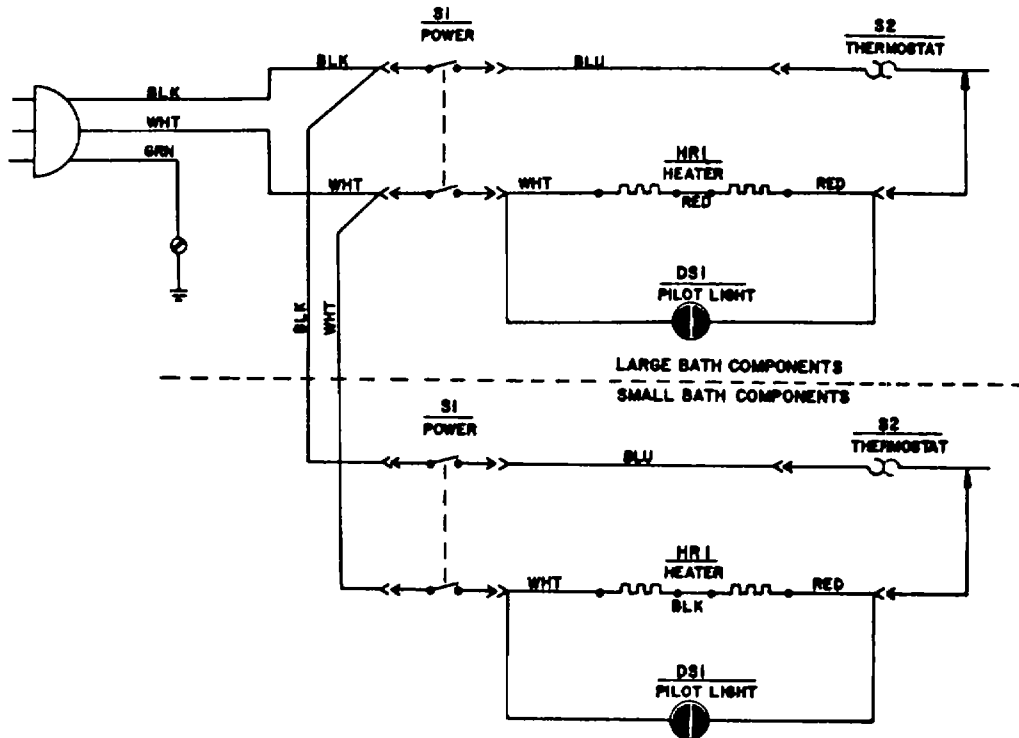

Exclusive Precision® Warranty

PRECISION SCIENTIFIC warrants its General purpose water baths against defects in material or in workmanship, when used under appropriate conditions and in accordance with appropriate operating instructions for a period of five (5) years on parts and one (1) year on labor from the date of delivery of the products.

Sole obligation of PRECISION SCIENTIFIC shall be to repair or replace at our option, FOB factory or locally, without charge, any part(s) that prove defective within the warranty period, provided the customer notifies PRECISION SCIENTIFIC promptly and in writing of any such defect. Compensation for labor by other than PRECISION SCIENTIFIC employees will not be our obligation. Part(s) replacement does not constitute an extension of the original warranty period.

PRECISION SCIENTIFIC MAKES NO WARRANTY OF MERCHANTABILITY, FITNESS FOR A PARTICULAR PURPOSE, OR ANY OTHER WARRANTY, EXPRESSED OR IMPLIED, AS TO THE DESIGN, SALE, INSTALLATION, OR USE OF ITS PRODUCTS, AND SHALL NOT BE LIABLE FOR CONSEQUENTIAL DAMAGES RESULTING FROM THE USE OF ITS PRODUCTS.

PRECISION SCIENTIFIC will not assume responsibility for unauthorized repairs or failure as a result of unauthorized product modifications, or for repairs, replacements, or modifications negligently or otherwise improperly made or performed by persons other than PRECISION SCIENTIFIC employees or authorized representatives.

While our personnel are available to advise customers concerning general applications of all manufactured products, oral representations are not warranties with respect to particular applications and should not be relied upon if inconsistent with product specifications or the terms stated herein.

In any event, the terms and conditions contained in PRECISION SCIENTIFIC formal sales contracts shall be controlling; and any changes must be in writing and signed by an authorized executive of PRECISION SCIENTIFIC.

All defective components will be replaced without charge five (5) year from the date of delivery. There will be no charge for labor for one (1) year if the apparatus is returned to the factory prepaid.

Conditions and qualifications of the warranty statement shall prevail at all times.

Precision® is a registered trademark of Precision Scientific Inc.

**APPENDIX A
REFERENCES**

A-1. **Scope.** This appendix contains all forms, pamphlets and technical manuals referenced in both the Air mobile and Semitrailer mounted Laboratories.

A-2. **Forms.**

Recommended Changes to Publications	DA Form 2028 DA Form 2028-2
Quality Deficiency Report	SF 368
Equipment Inspection and Maintenance Work Sheet	DA Form 2404
Hand Receipts	DA Form 2062

A-3. **Field Manuals.**

Petroleum Testing Facilities' Laboratories and Kits	FM 10-72
Inspecting and Testing Petroleum Products	FM 10-70
ASTM Test Method Supplement to	FM 10-92C1/C2

A-4. **Technical Manuals.**

Atlas-Copco Compressor	TM 10-4310-392-13&P
Alcor Jet Fuel Thermal Oxidation Tester Operating and Maintenance Manual	TM 10-6635-210-13&P
Bacharach Gas Alarm and Calibration Data	TM 10-6665-297-13&P
Brother Portable Typewriter	TM 10-7430-218-13&P
Chemtrix Field Ph Meter	TM 10-6630-237-13&P
Elkay Manufacturing 30 GPH Cooler	TM 10-4130-240-13&P
Emcee Micro-Separometer	TM 10-6640-222-13&P
Foxboro Pressure Recording Gauge	TM 10-6685-365-13&P
Gammon Aqua Glo Water Detector	TM 10-6640-221-13&P
Gammon Mini Monitor Fuel Sampling Kit	TM 10-6630-230-13&P
Jelrus Burn-Out Furnace	TM 10-6640-231-13&P
Koehler Cleveland Open Tester	TM 10-6630-236-13&P
Koehler Cloud and Pour Point Chamber	TM 10-6630-238-13&P
Koehler Copper Strip Corrosion Bomb Bath	TM 10-6640-220-13&P
Koehler Distillation Apparatus	TM 10-6630-233-13&P
Koehler Dropping Point Apparatus	TM 10-6635-211-13&P
Koehler Electric Pensky-Martins Tester	TM 10-6630-231-13&P
Koehler Foaming Characteristics Determination Apparatus	TM 10-6640-228-13&P
Koehler Kinematic Viscosity Bath	TM 10-6630-239-13&P
Koehler Tag Closed Cup Flash Tester	TM 10-6630-235-13&P
Lab-Line Explosion Proof Refrigerator	TM 10-6640-219-13&P
Lily Freezer	TM 10-6640-234-13&P
Millipore OM 39 Filter Holder	TM 10-6640-225-13&P
Millipore Vacuum Pump	TM 10-6640-217-13&P
Ohaus Harvard Trip Balance	TM 10-6670-278-13&P
Precision Gas-Oil Distillation Test Equipment	TM 10-6630-219-13&P
Precision General Purpose Water Bath	TM 10-6640-229-13&P

Precision High Temperature Bronze Block Gum Bath	TM 10-6630-234-13&P
Precision General Purpose Ovens	TM 10-6640-218-13&P
Precision Heater Instruction Manual and Parts List	TM 10-6640-223-13&P
Precision Oxidation Stability Bath	TM 10-6640-232-13&P
Precision Pensky-Martens Flash Testers	TM 10-6630-231-13&P
Precision Reid Vapor Pressure Bath	TM 10-6640-226-13&P
Precision Slo-Speed Stirrer	TM 10-6640-224-13&P
Precision Universal Centrifuge	TM 10-6640-230-13&P
Precision Universal Penetrometer	TM 10-6640-228-13&P
Sargent-Welch Vacuum Pump	TM 10-4310-391-13&P
Sartorius Analytical Balance	TM 10-6670-277-13&P
Scotsman Cuber	TM 10-6640-227-13&P
Soltec VOM-Multimeter	TM 10-6625-3127-13&P
Teel Self-Priming Centrifugal Pump	TM 10-6640-217-13&P
Teel Submersible Pump	TM 10-4320-320-13&P
Texas Instrument TI-503011 Calculator	TM 10-7420-210-13&P

A-5. Pamphlets.

The Army Maintenance Management System (TAMMS)	DA Pam 738-750
--	----------------

A-6. Miscellaneous Publications.

The Army Integrated Publishing and Printing Program	AR 25-30
Laboratory, Airmobile, Aviation Fuel	MIL-L-52733A(ME)
Apparatus, Instruments, Chemicals, Furniture, and Supplies for Industrial, Clinical, College and Government Laboratories	Fisher Scientific Laboratories Catalog
Petroleum-Petrochemical Testing Equipment	Precision Scientific Catalog

APPENDIX B

MAINTENANCE ALLOCATION CHART

Section I. INTRODUCTION

B-1 **General.**

a. This section provides a general explanation of all maintenance and repair functions authorized at various maintenance categories.

b. The Maintenance Allocation Chart (MAC) in Section II designates overall authority and responsibility for the performance of maintenance functions on the identified end item or component. The application of the maintenance functions to the end item or component will be consistent with the capacities and capabilities of the designated maintenance categories.

c. Section III lists the tools and test equipment (both special tools and common tool sets) required for each maintenance function as referenced from Section II.

d. Section IV contains supplemental instructions and explanatory notes for a particular maintenance function.

B-2 **Maintenance Functions.** Maintenance functions will be limited to and defined as follows:

a. Inspect. To determine the serviceability of an item by comparing its physical, mechanical, and/or electrical characteristics with established standards through examination (e.g., by sight, sound, or feel).

b. Test. To verify serviceability by measuring the mechanical, pneumatic, hydraulic, or electrical characteristics of an item and comparing those characteristics with prescribed standards.

c. Service. Operations required periodically to keep an item in proper operating condition, i.e., to clean (includes decontaminate, when required), to preserve, to drain, to paint, or to replenish fuel, lubricants, chemical fluids, or gases.

d. Adjust. To maintain or regulate, within prescribed limits, by bringing into proper or exact position, or by setting the operating characteristics to specified parameters.

e. Align. To adjust specified variable elements of an item to bring about optimum or desired performance.

f. Calibrate. To determine and cause corrections to be made or to be adjusted on instruments or test, measuring, and diagnostic equipments used in precision measurement. Consists of comparisons of two instruments, one of which is a certified standard of knob accuracy, to detect and adjust any discrepancy in the accuracy of the instrument being compared.

g. Remove/Install. To remove and install the same item when required to perform service or other maintenance functions. Install may be the act of emplacing, seating, or fixing into position a spare, repair part, or module (component or assembly) in a manner to allow the proper functioning of an equipment or system.

h. Replace. To remove an unserviceable item and install a serviceable counterpart in its place. "Replace" is authorized by the MAC and is shown as the third position code of the SMR code.

i. Repair. The application of maintenance services, ¹including fault location/troubleshooting,² removal/installation, and disassembly/assembly procedures,³ and maintenance actions,⁴ to identify troubles and restore serviceability to an item by correcting specific damage, fault, malfunction, or failure in a part, subassembly, module (component or assembly), end item, or system

j. Overhaul That maintenance effort (service/action) prescribed to restore an item to a completely serviceable/operational condition as required by maintenance standards in appropriate technical publications (i.e., DMWR) Overhaul is normally the highest degree of maintenance performed by the Army. Overhaul does not normally return an item to like-new condition

k. Rebuild. Consists of those services/actions necessary for the restoration of unserviceable equipment to a like-new condition in accordance with original manufacturing standards. Rebuild is the highest degree of materiel maintenance applied to Army equipment. The rebuild operation Includes the act of returning to zero those age measurements (hours/miles, etc.) considered in classifying Army equipment/components.

B-3. Explanation Of Columns In the MAC, Section II.

a. Column 1. Group Number Column 1 lists functional group code numbers, the purpose of which is to identify maintenance significant components, assemblies, subassemblies, and modules with the next higher assembly. End item group number shall be "00 "

b. Column 2. Component/Assembly. Column 2 contains the names of components, assemblies, subassemblies, and modules for which maintenance is authorized.

c. Column 3. Maintenance Function Column 3 lists the functions to be performed on the item listed in column 2. (For a detailed explanation of these functions, see paragraph B-2)

d. Column 4. Maintenance Category Column 4 specifies, by the listing of a work time figure In the appropriate subcolumn(s), the category of maintenance authorized to perform the function listed In column 3. This figure represents the active time required to perform that maintenance function at the indicated category of maintenance. If the number or complexity of the tasks within the listed maintenance function vary at different maintenance categories, appropriate work time figures will be shown for each category. The work time figure represents the average time required to restore an item (assembly, subassembly, component, module, end item, or system) to a serviceable condition under typical field operating conditions This time includes preparation time (including any necessary disassembly/assembly time), troubleshooting/fault location time, and quality assurance/quality control time in addition to the time required to perform the specific tasks identified for the maintenance functions authorized in the maintenance allocation chart The symbol designations for the various maintenance categories are as follows:

-
- 1 *Services - inspect, test, service, adjust, align, calibrate, and/or replace.*
 - 2 *Fault locate/troubleshoot - the process of investigating and detecting the cause of equipment malfunctioning, the act of isolating a fault within a system or unit under test (UUT).*
 - 3 *Disassemble/assemble - encompasses the step by-step taking apart (or breakdown) of a spare/functional group coded item to the level of its least componency identified as maintenance significant (/ e, assigned an SMR code) for the category of maintenance under consideration.*
 - 4 *Actions - welding, grinding, riveting, straightening, facing, remachining, and/or resurfacing*

- C Operator/Crew
- O Unit Maintenance
- F Direct Support Maintenance
- H General Support Maintenance
- D Depot Maintenance

e. Column 5. Tools and Equipment. Column 5 specifies, by code, those common tool sets (not individual tools) and special tools, TMDE, and support equipment required to perform the designated function

f. Column 6. Remarks. This column shall, when applicable, contain a letter code, In alphabetic order, which shall be keyed to the remarks contained In section 1V

B-4. Explanation Of Columns In Tool And Test Equipment Requirements, Section III.

a. Column 1. Reference Code. The tool and test equipment reference code correlates with a code used in the MAC, section II, column 5.

b. Column 2. Maintenance Category. The lowest category of maintenance authorized to use the tool or test equipment.

c. Column 3. Nomenclature. Name or identification of the tool or test equipment

d. Column 4. National Stock Number. The National stock number of the tool or test equipment.

e. Column 5. Tool Number. The manufacturer's part number

B-5. Explanation Of Columns In Remarks, Section IV.

a. Column 1. Reference Code. The code recorded In Column 6, Section II

b. Column 2. Remarks. This column lists Information pertinent to the maintenance function being performed as indicated in the MAC, section II

Section II. MAINTENANCE ALLOCATION CHART

(1) GROUP NUMBER	(2) COMPONENT ASSEMBLY	(3) MAINTENANCE FUNCTION	MAINTENANCE LEVEL					(5) TOOLS AND EQUIP.	(6) REMARKS
			UNIT		DS	GS	DEPOT		
			C	O	F	H	D		
01	WATER BATHS, GENERALPURPOSE	INSPECT REPLACE REPAIR	0.1	0.2	1.0			1, 2, 3	

**Section III. TOOL AND TEST EQUIPMENT REQUIREMENTS
MAINTENANCE ALLOCATION CHART**

(1) TOOL/TEST EQUIP. REF CODE	(2) MAINTENANCE CATEGORY	(3) NOMENCLATURE	(4) NSN	(5) TOOL NUMBER
1	O	TOOL KIT, GENERAL AUTOMOTIVE	5180-00-177-7033	(50980) SC 5180-90- CL-N26
2	O	MULTIMETER, 0-500V	6625-00-691-2453	
3	O	KIT, SOLDERING GUN, 115V, 60 CYCLE COMPLETE WITH SOLDER AND CASE	3439-00-618-6623	

Section IV. REMARKS

NOT APPLICABLE

APPENDIX C

COMPONENTS OF END ITEM AND BASIC ISSUE ITEMS LISTS

Section I. INTRODUCTION

C-1 **Scope.**

This appendix lists components of end item and basic issue items for the Precision General Purpose Water Baths to help you inventory items required for safe and efficient operation.

C-2 **General.**

The Components of End Item and Basic Issue Items Lists are divided into the following sections.

a. Section II. Components of End Item. This listing is for informational purposes only, and is not authority to requisition replacements. These items are part of the end item, but are removed and separately packaged for transportation or shipment. As part of the end item, these items must be with the end item whenever it is issued or transferred between property accounts. Illustrations are furnished to assist you in identifying the items.

b. Section III Basic Issue Items. These are the minimum essential items required to place the Precision General Purpose Water Baths in operation, to operate it, and to perform emergency repairs. Although shipped separately packaged, BII must be with the shelter during operation and whenever it is transferred between property accounts. The illustrations will assist you with hard-to-identify items. This manual is your authority to request/requisition replacement BII, based on TOE/MTOE authorization of the end item.

C-3. **Explanation of Columns.**

The following provides an explanation of columns found in the tabular listings

a. Column (1) - Illustration Number (Illus Number). This column indicates the number of the illustration in which the item is shown.

b. Column (2) - National Stock Number. Indicates the National stock number assigned to the item and will be used for requisitioning purposes

c. Column (3) - Description. Indicates the Federal item name and, if required, a minimum description to identify and locate the item. The last line for each item indicates the CAGEC (in parentheses) followed by the part number

d. Column (4) - Unit of Measure (U/M). Indicates the measure used in performing the actual operational / maintenance function. This measure is expressed by a two-character alphabetical abbreviation (e.g., ea., in, pr).

e. Column (5) - Quantity required (QTY RQF). Indicates the quantity of the item authorized to be used with/on the equipment.

Section II. COMPONENTS OF END ITEM

(1) Illus	(2) National Stock Number	(3) Description CAGEC And Part Number	Usable On Code	(4) U/M	(5) Qty
		THERMOMETER (48619) 31495			

**Section III. BASIC ISSUE ITEMS
NOT APPLICABLE**

APPENDIX D
ADDITIONAL AUTHORIZATION LIST

NOT APPLICABLE

APPENDIX E

EXPENDABLE/DURABLE SUPPLIES AND MATERIALS LIST

NOT APPLICABLE

By Order of the Secretary of the Army:

CARL E. VUONO
General, United States Army
Chief of Staff

Official:

THOMAS F. SIKORA
Brigadier General, United States Army
The Adjutant General

DISTRIBUTION:

To be distributed in accordance with DA Form 12-21A, Operator, Unit and Direct Support Maintenance requirements for Laboratory, Petroleum, MTD

RECOMMENDED CHANGES TO EQUIPMENT TECHNICAL PUBLICATIONS

 <div style="border: 1px solid black; border-radius: 15px; padding: 5px; display: inline-block; margin-left: 20px;"> <p style="font-size: small; margin: 0;"><i>THEN...JOT DOWN THE DOPE ABOUT IT ON THIS FORM. CAREFULLY TEAR IT OUT, FOLD IT AND DROP IT IN THE MAIL.</i></p> </div>		SOMETHING WRONG WITH PUBLICATION	
		FROM: (PRINT YOUR UNIT'S COMPLETE ADDRESS)	
		DATE SENT	
PUBLICATION NUMBER		PUBLICATION DATE	PUBLICATION TITLE
IN THIS SPACE, TELL WHAT IS WRONG AND WHAT SHOULD BE DONE ABOUT IT.			
BE EXACT PIN-POINT WHERE IT IS			
PAGE NO.	PARA-GRAPH	FIGURE NO.	TABLE NO.
PRINTED NAME, GRADE OR TITLE AND TELEPHONE NUMBER		SIGN HERE	

The Metric System and Equivalents

Linear Measure

1 centimeter = 10 millimeters = .39 inch
 1 decimeter = 10 centimeters = 3.94 inches
 1 meter = 10 decimeters = 39.37 inches
 1 dekameter = 10 meters = 32.8 feet
 1 hectometer = 10 dekameters = 328.08 feet
 1 kilometer = 10 hectometers = 3,280.8 feet

Weights

1 centigram = 10 milligrams = .15 grain
 1 decigram = 10 centigrams = 1.54 grains
 1 gram = 10 decigram = .035 ounce
 1 decagram = 10 grams = .35 ounce
 acres
 1 hectogram = 10 decagrams = 3.52 ounces
 1 kilogram = 10 hectograms = 2.2 pounds
 1 quintal = 100 kilograms = 220.46 pounds
 1 metric ton = 10 quintals = 1.1 short tons

Liquid Measure

1 centiliter = 10 milliliters = .34 fl. ounce
 1 deciliter = 10 centiliters = 3.38 fl. ounces
 1 liter = 10 deciliters = 33.81 fl. ounces
 1 dekaliter = 10 liters = 2.64 gallons
 1 hectoliter = 10 dekaliters = 26.42 gallons
 1 kiloliter = 10 hectoliters = 264.18 gallons

Square Measure

1 sq. centimeter = 100 sq. millimeters = .155 sq. inch
 1 sq. decimeter = 100 sq. centimeters = 15.5 sq. inches
 1 sq. meter (centare) = 100 sq. decimeters = 10.76 sq. feet
 1 sq. dekameter (are) = 100 sq. meters = 1,076.4 sq. feet
 1 sq. hectometer (hectare) = 100 sq. dekameters = 2.47
 1 sq. kilometer = 100 sq. hectometers = .386 sq. mile

Cubic Measure

1 cu. centimeter = 1000 cu. millimeters = .06 cu. inch
 1 cu. decimeter = 1000 cu. centimeters = 61.02 cu. inches
 1 cu. meter = 1000 cu. decimeters = 35.31 cu. feet

Approximate Conversion Factors

<i>To change</i>	<i>To</i>	<i>Multiply by</i>	<i>To change</i>	<i>To</i>	<i>Multiply by</i>
inches	centimeters	2.540	ounce-inches	Newton-meters	.007062
feet	meters	.305	centimeters	inches	.394
yards	meters	.914	meters	feet	3.280
miles	kilometers	1.609	meters	yards	1.094
square inches	square centimeters	6.451	kilometers	miles	.621
square feet	square meters	.093	square centimeters	square inches	.155
square yards	square meters	.836	square meters	square feet	10.764
square miles	square kilometers	2.590	square meters	square yards	1.196
acres	square hectometers	.405	square kilometers	square miles	.386
cubic feet	cubic meters	.028	square hectometers	acres	2.471
cubic yards	cubic meters	.765	cubic meters	cubic feet	35.315
fluid ounces	milliliters	29,573	cubic meters	cubic yards	1.308
pints	liters	.473	milliliters	fluid ounces	.034
quarts	liters	.946	liters	pints	2.113
gallons	liters	3.785	liters	quarts	1.057
ounces	grams	28.349	liters	gallons	.264
pounds	kilograms	.454	grams	ounces	.035
short tons	metric tons	.907	kilograms	pounds	2.205
pound-feet	Newton-meters	1.356	metric tons	short tons	1.102
pound-inches	Newton-meters	.11296			

Temperature (Exact)

°F	Fahrenheit temperature	5/9 (after subtracting 32)	Celsius temperature	°C
----	---------------------------	-------------------------------	------------------------	----

